

The Needle and the Damage Done

Neil Young

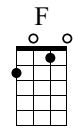
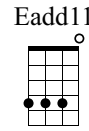
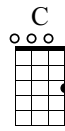
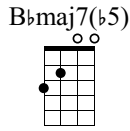
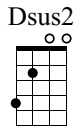
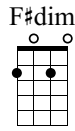
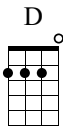

Ukulele

Low G

① = A ③ = C

② = E ④ = G

♩ = 105

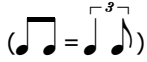

D

F#dim

Dsus2

Bbmaj7(b5)

uke.

Ukulele tablature for measures 1-4. Measure 1: D (2 3 4 0), F#dim (2 3 3 4), Dsus2 (2 2 2 2), Bbmaj7(b5) (2 2 2 2). Measure 2: D (2 3 4 0), F#dim (4 2 4 3), Dsus2 (4 3 2 2), Bbmaj7(b5) (2 2 2 2). Measure 3: D (2 3 4 0), F#dim (2 2 2 2), Dsus2 (2 2 2 2), Bbmaj7(b5) (2 2 2 2). Measure 4: D (2 3 4 0), F#dim (2 2 2 2), Dsus2 (2 2 2 2), Bbmaj7(b5) (2 2 2 2).

voc.

Vocal staff for measures 1-4, showing a whole rest.

C

Dsus2

Eadd11

uke.

Ukulele tablature for measures 5-8. Measure 5: C (0 0 0 2), Dsus2 (0 0 0 0), Eadd11 (0 0 0 0). Measure 6: C (0 0 0 2), Dsus2 (0 0 0 0), Eadd11 (0 0 0 0). Measure 7: C (0 0 0 2), Dsus2 (0 0 0 0), Eadd11 (0 0 0 0). Measure 8: C (0 0 0 2), Dsus2 (0 0 0 0), Eadd11 (0 0 0 0).

voc.

Vocal staff for measures 5-8, showing a whole rest.

D

F#dim

Dsus2

Bbmaj7(b5)

uke.

Ukulele tablature for measures 9-12. Measure 9: D (2 3 4 0), F#dim (2 3 3 4), Dsus2 (2 2 2 2), Bbmaj7(b5) (2 2 2 2). Measure 10: D (2 3 4 0), F#dim (4 2 4 3), Dsus2 (4 3 2 2), Bbmaj7(b5) (2 2 2 2). Measure 11: D (2 3 4 0), F#dim (2 2 2 2), Dsus2 (2 2 2 2), Bbmaj7(b5) (2 2 2 2). Measure 12: D (2 3 4 0), F#dim (2 2 2 2), Dsus2 (2 2 2 2), Bbmaj7(b5) (2 2 2 2).

voc.

Vocal staff for measures 9-12 with lyrics: "I caught you knock-ing at my cel-lar door I love you ba-by can I have some more".

C

F

Dsus2

Eadd11

uke.

Ukulele tablature for measures 13-16. Measure 13: C (0 4 0 0), F (0 4 4 0), Dsus2 (0 0 0 0), Eadd11 (0 0 0 0). Measure 14: C (0 4 0 0), F (0 0 0 0), Dsus2 (0 0 0 0), Eadd11 (0 0 0 0). Measure 15: C (0 4 0 0), F (0 0 0 0), Dsus2 (0 0 0 0), Eadd11 (0 0 0 0). Measure 16: C (0 4 0 0), F (0 0 0 0), Dsus2 (0 0 0 0), Eadd11 (0 0 0 0).

voc.

Vocal staff for measures 13-16 with lyrics: "Oooh, oooh the dam-age done".

17 **D** **F#dim** **Dsus2** **Bbmaj7(b5)**

uke.

voc.

I hit the ci- ty and I lost my band I watched the nee- dle take a- no- ther man

21 **C** **F** **Dsus2** **Eadd11** **H** **H**

uke.

voc.

Gone, gone, the dam- age done

25 **D** **F#dim** **Dsus2** **Bbmaj7(b5)**

uke.

voc.

29 **C** **Dsus2** **Eadd11**

uke.

voc.

33 **D** **F#dim** **Dsus2** **Bbmaj7(b5)**

uke.

voc.

I sing the song be- cause I love the man I know that some of you don't un- der- stand

37 C F Dsus2 Eadd11 H H

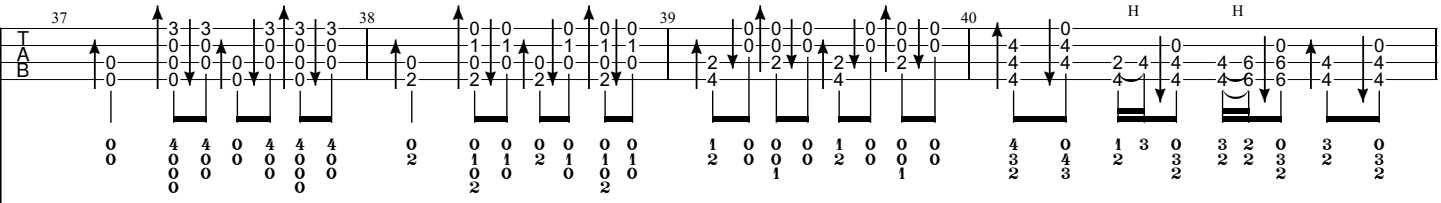
uke. 

voc. 

Milk- blood to keep from run- ning out.

41 D F#dim Dsus2 Bbmaj7(b5)

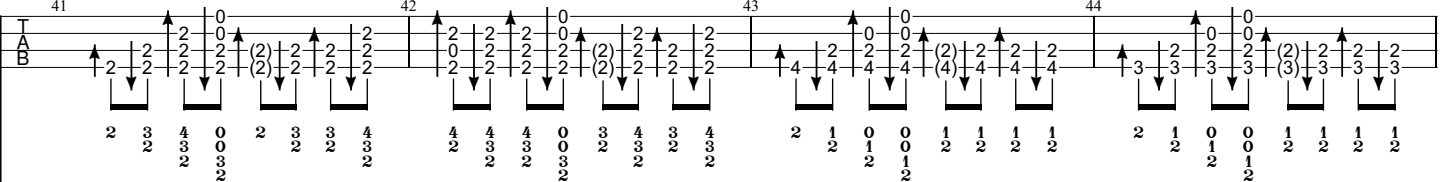

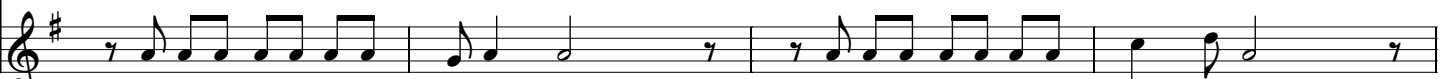

I've seen the nee- dle and the da- mage done A lit- tle part of it in e- very- one

45 C F Dsus2 Eadd11 H H

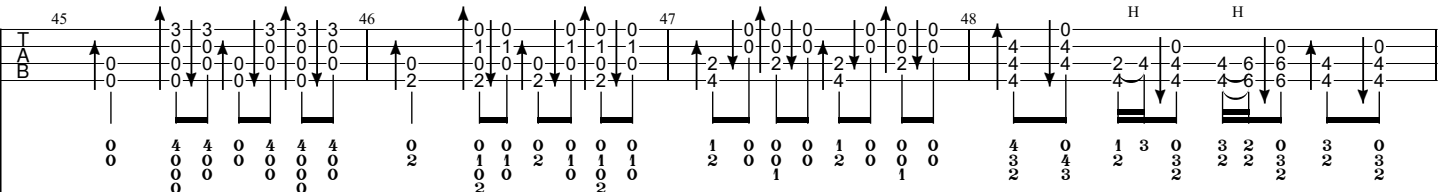



But ev- ery jun- kie's like a set- tin' sun.

49 D F#dim Dsus2 Bbmaj7(b5)

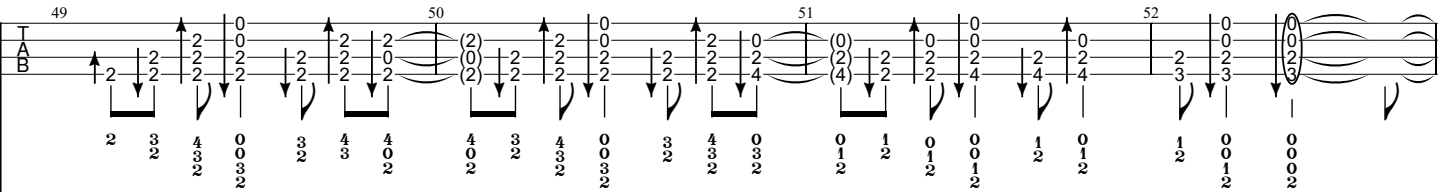

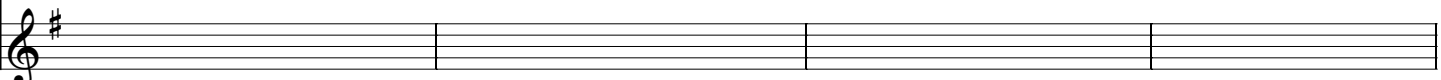

53 54 55

