

I walk the line

Johnny Cash

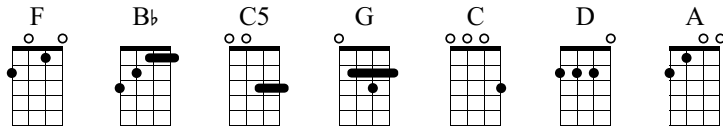

Ukulele

Low G

① = A ③ = C

② = E ④ = G

$\text{♩} = 104$

1 **F**

uke.

voc.

B \flat **F**

uke.

voc.

C5 **G**

uke.

voc.

C

uke.

voc.

Mmmmm

9

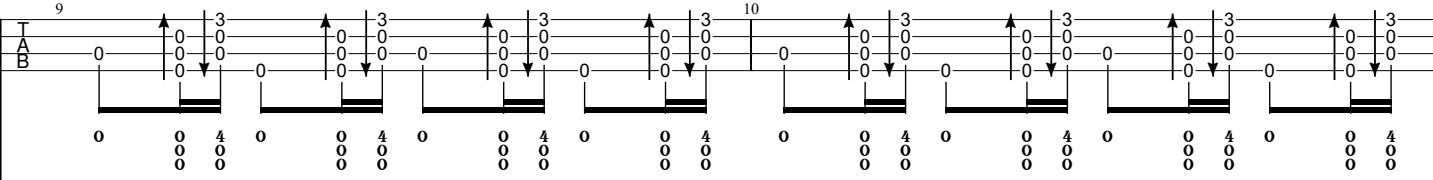
uke. 

voc. 

11

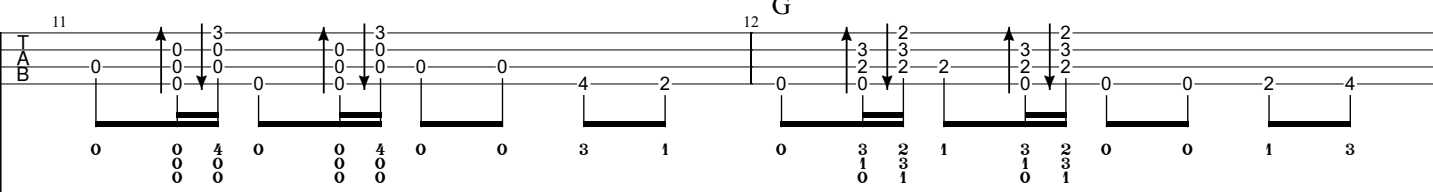
uke. 

voc. 

I keep a close watch on this heart of

13

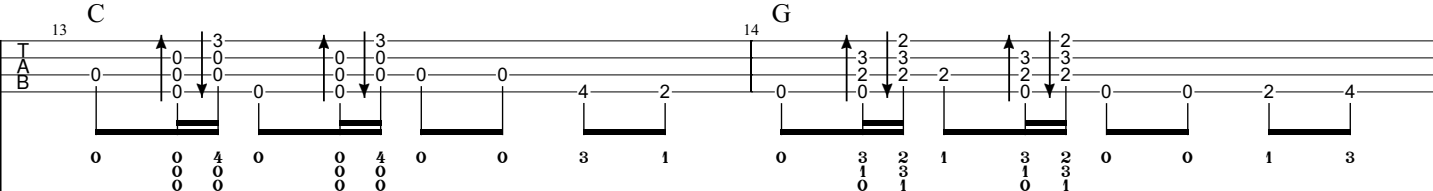
uke. 

voc. 

mine I keep my eyes wide o- pen all the

15

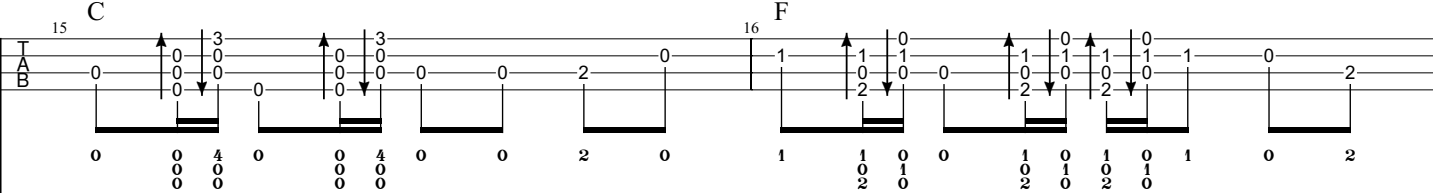
uke. 

voc. 

time I keep the ends out for the tie that

17

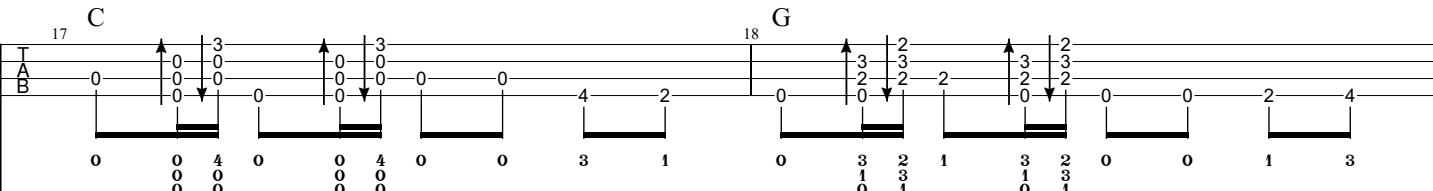
uke. 

voc. 

binds Be- cause your mine I walk the

19 **C** **D**

uke.

voc.

21 **D** **D**

uke.

voc.

23 **D** **A**

uke.

voc.

I find it ve- ry ve- ry ea- sy to be

25 **D** **A**

uke.

voc.

true I find my self a- lone when each day is

27 **D** **G**

uke.

voc.

through Yes, I'll ad- mit that I'm a fool for

29 **D** **A**

uke.

voc.

you Be- cause your mine I walk the

31 **D** **G**

uke.

voc.

line mmmmm

33 **D** **G**

uke.

voc.

35 **D** **D**

uke.

voc.

As sure as night is dark and day is

37 **G** **D**

uke.

voc.

light I keep you on my mind both day and

39 **G** **C5**

uke.

voc.

night And hap- pi- ness I've known proves that it's

41 **G** **D**

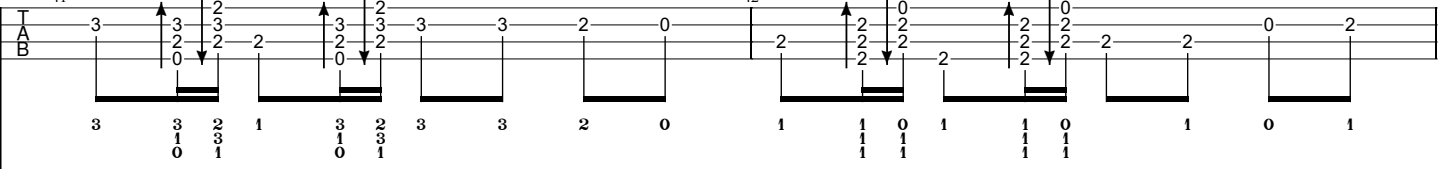
uke. 

voc. 

right Be- cause your mine I walk the

43 **G** **D**

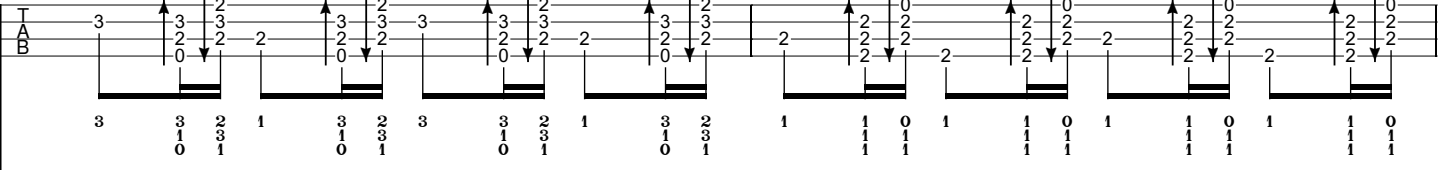
uke. 

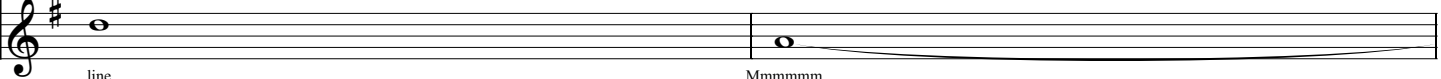
voc. 

line Mmmmm

45 **D** **D**

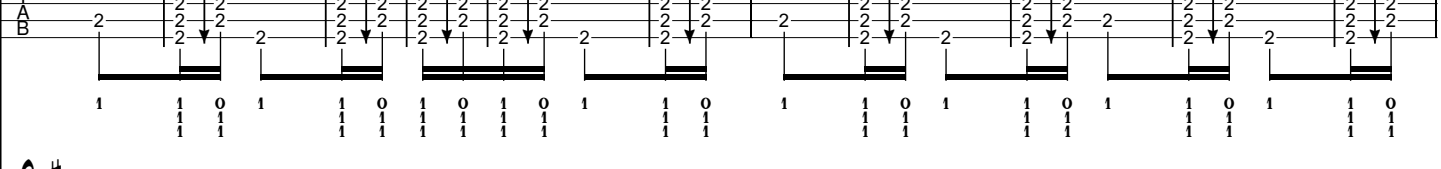
uke. 

voc. 

47 **A** **A**

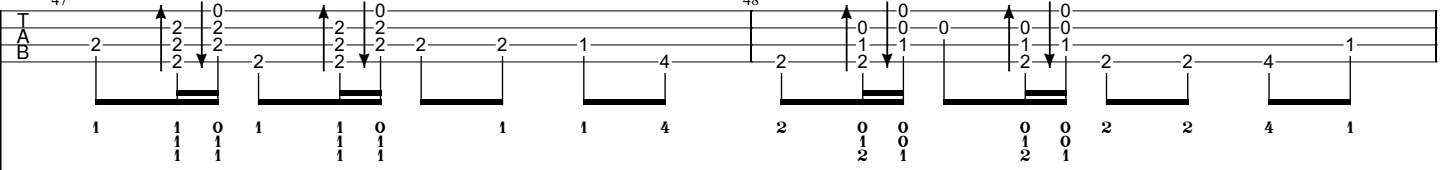
uke. 

voc. 

You've got a way to keep me on your

49 **D** **A**

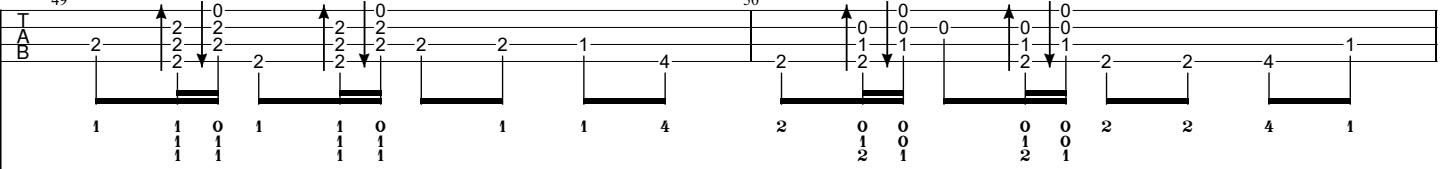
uke. 

voc. 

side You give me cause for love that I can't

51 **D** **G**

1 1 0 1 3 3 2 0 1 3 2 3 3 2 0

hide For you I know I'd e- ven try to turn the

53 **D** **A**

1 1 0 1 2 0 0 0 2 2 4 1

tide Be- cause your mine I walk the

55 **D** **C**

1 1 0 1 0 0 4 0 0 0 4 0 0 0 4 0 0 0 4 0

line Mmmmm

57 **D** **C**

0 0 4 0 0 0 4 0 0 0 4 0 0 0 4 0 0 0 4 0

59 **D** **G**

0 0 4 0 0 0 3 1 0 3 2 2 1 3 2 2 0 0 1 3

I keep a close watch on this heart of

61 **C** **G**

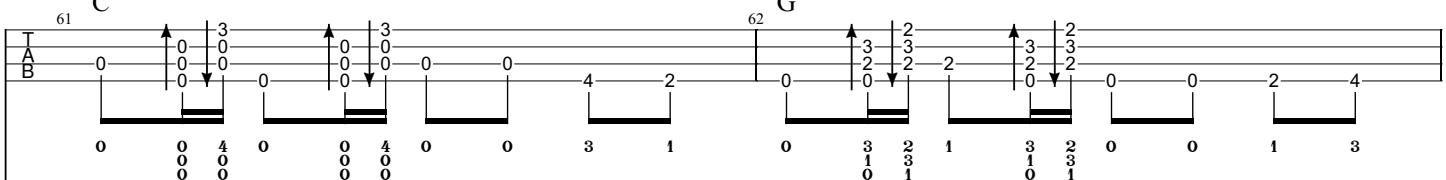
uke. 

voc. 

mine I keep my eyes wide o- pen all the

63 **C** **F**

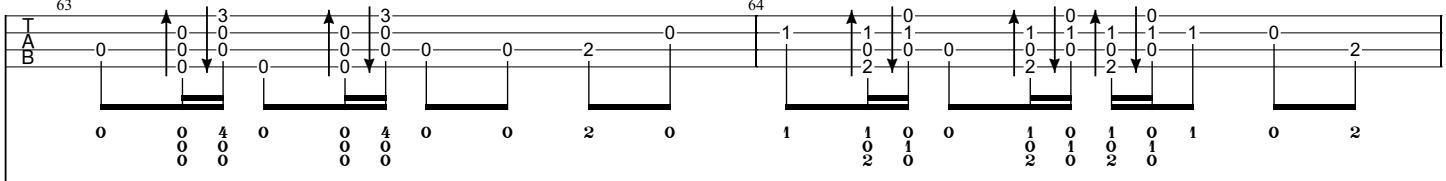
uke. 

voc. 

time I keep the ends out for the tie that

65 **C** **G**

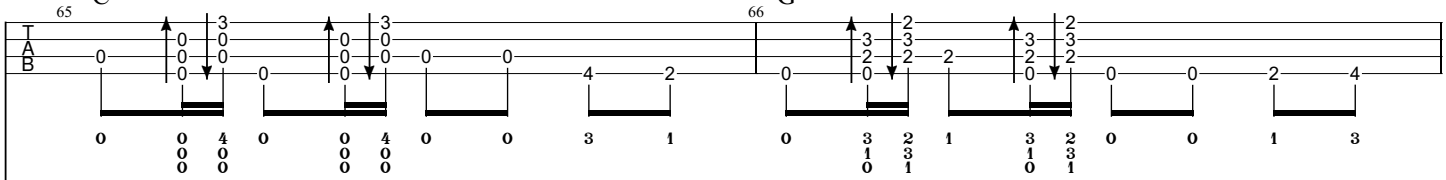
uke. 

voc. 

binds Be- cause your mine I walk the

67 **C** **C**

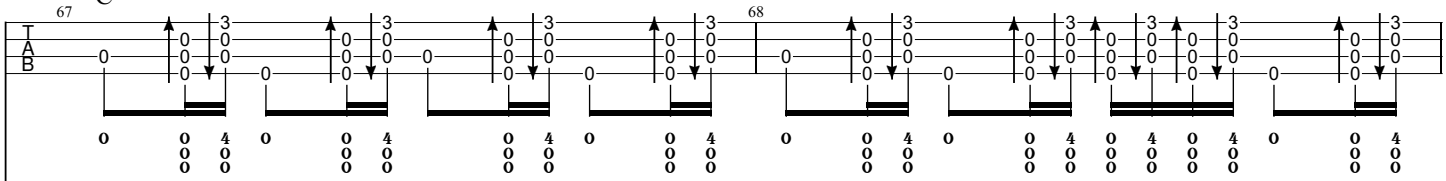
uke. 

voc. 

line

69 **C** **C** **C** **C** **C** **C** **C** **C**

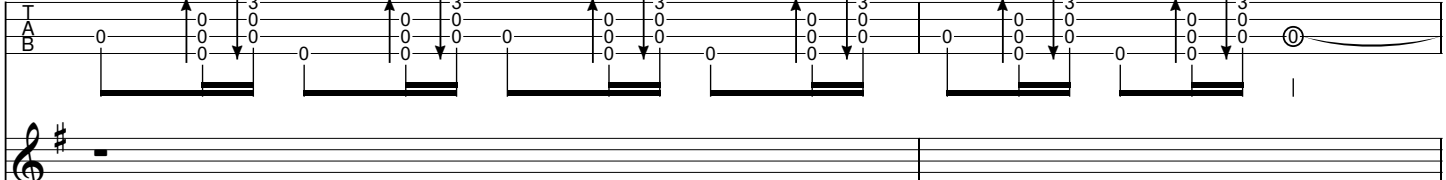
uke. 

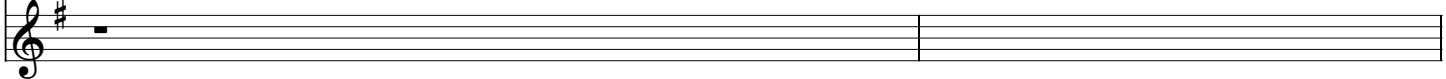
voc. 

71 **C** **C** **C** **C** **C** **C** **C** **C**

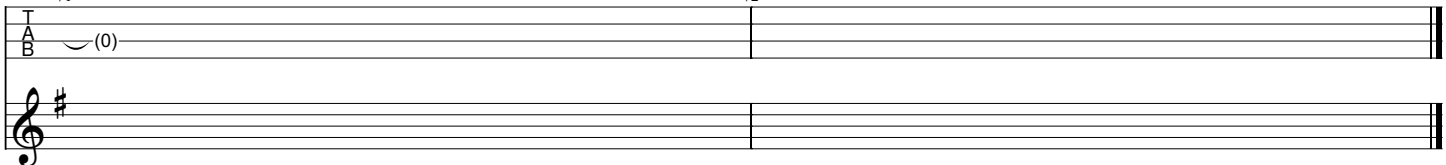
uke. 

voc. 